

Features :

- n Center amplifying gate
- n Metal case with ceramic insulator
- n Low on-state and switching losses

Typical Applications

- n AC controllers
- n DC and AC motor control
- n Controlled rectifiers

Part No. DST1600-KT50cT

I_{T(AV)}	1540A
V_{DRM}, V_{RDM}	1200V 1400V
	1600V 1800V

SYMBOL	CHARACTERISTIC	TEST CONDITIONS		T _J (°C)	VALUE			UNIT
					Min	Type	Max	
I _{T(AV)}	Mean on-state current	180° half sine wave 50Hz Double side cooled	T _C =70°C	125			1540	A
V _{DRM} V _{RDM}	Repetitive peak off-state voltage Repetitive peak reverse voltage	tp=10ms		125	1100		1800	V
I _{DRM} I _{RDM}	Repetitive peak current	at V _{DRM} at V _{RDM}		125			80	mA
I _{TSM}	Surge on-state current	10ms half sine wave		125			24	kA
I ² t	I ² t for fusing coordination	V _R =0.6V _{RDM}					2880	A ² s*10 ³
V _{TO}	Threshold voltage			125			0.91	V
r _T	On-state slope resistance						0.23	mΩ
V _{TM}	Peak on-state voltage	I _{TM} =3000A, F=24kN		25			2.10	V
dv/dt	Critical rate of rise of off-state voltage	V _{DM} =0.67V _{DRM}		125			1000	V/μs
di/dt	Critical rate of rise of on-state current	V _{DM} = 67%V _{DRM} to2000A, Gate pulse t _r ≤0.5μs I _{GM} =1.5A		125			150	A/μs
Q _{rr}	Recovery charge	I _{TM} =1000A, tp=4000μs, di/dt=-20A/μs, V _R =100V		125		1500		μC
I _{GT}	Gate trigger current	V _A =12V, I _A =1A		25	40		300	mA
V _{GT}	Gate trigger voltage		0.8			3.0	V	
I _H	Holding current		20			300	mA	
I _L	Latching current					500	mA	
V _{GD}	Non-trigger gate voltage	V _{DM} =67%V _{DRM}		125			0.3	V
R _{th(j-c)}	Thermal resistance Junction to case	At 180° sine double side cooled Clamping force 24kN					0.020	°C /W
R _{th(c-h)}	Thermal resistance case to heatsink						0.005	
F _m	Mounting force				19		26	kN
T _{vj}	Junction temperature				-40		125	°C
T _{stg}	Stored temperature				-40		140	°C
W _t	Weight					440		g
Outline	KT50cT							

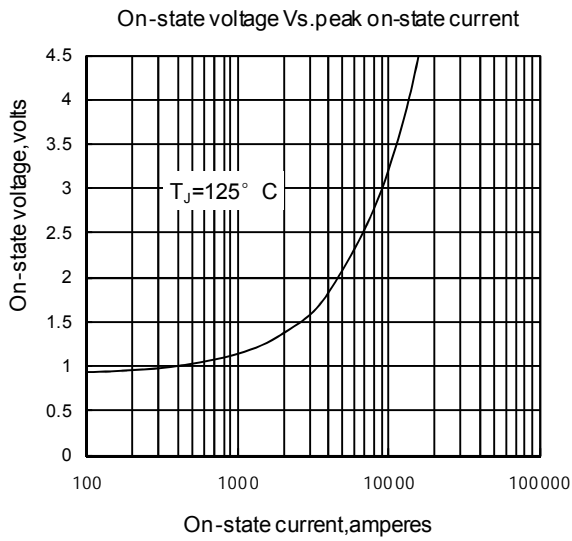

Fig 1

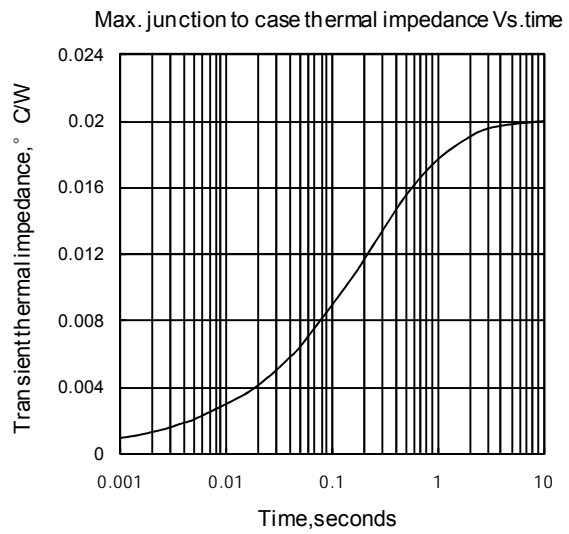

Fig 2

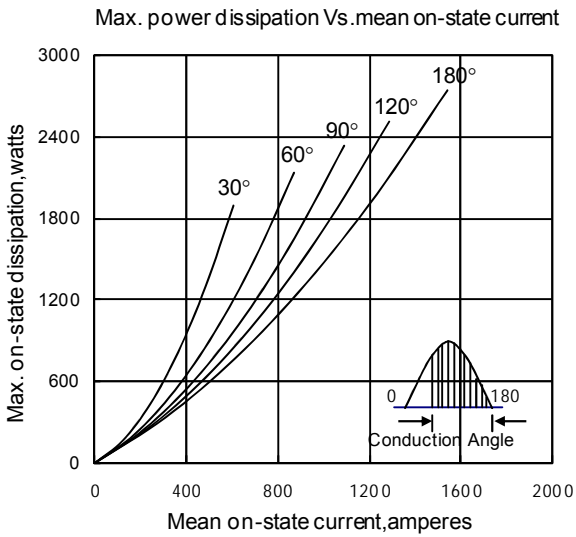

Fig 3

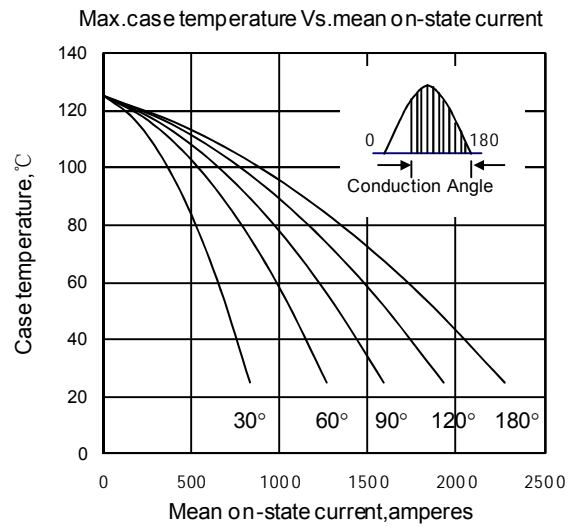

Fig 4

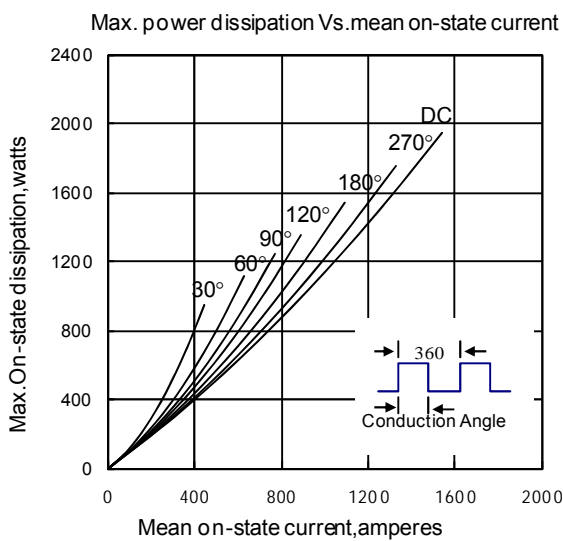

Fig 5

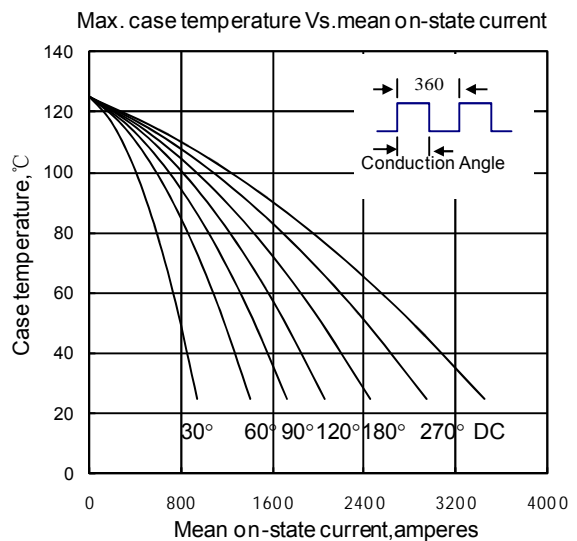

Fig 6

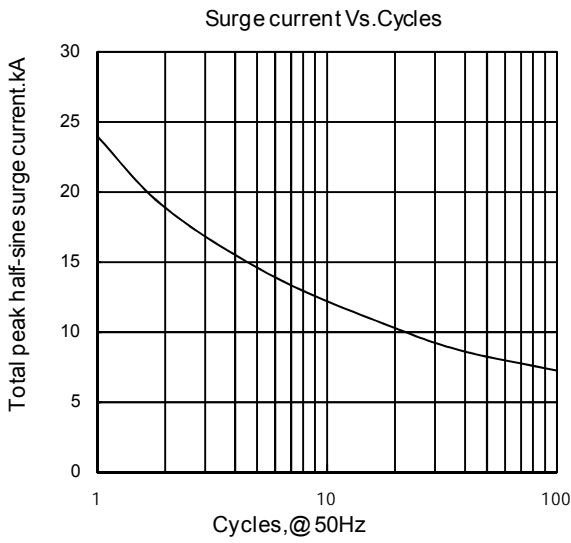
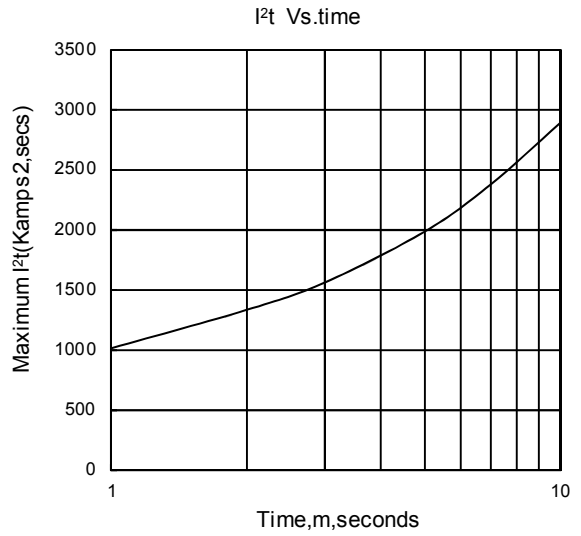

Fig7



Fi g8

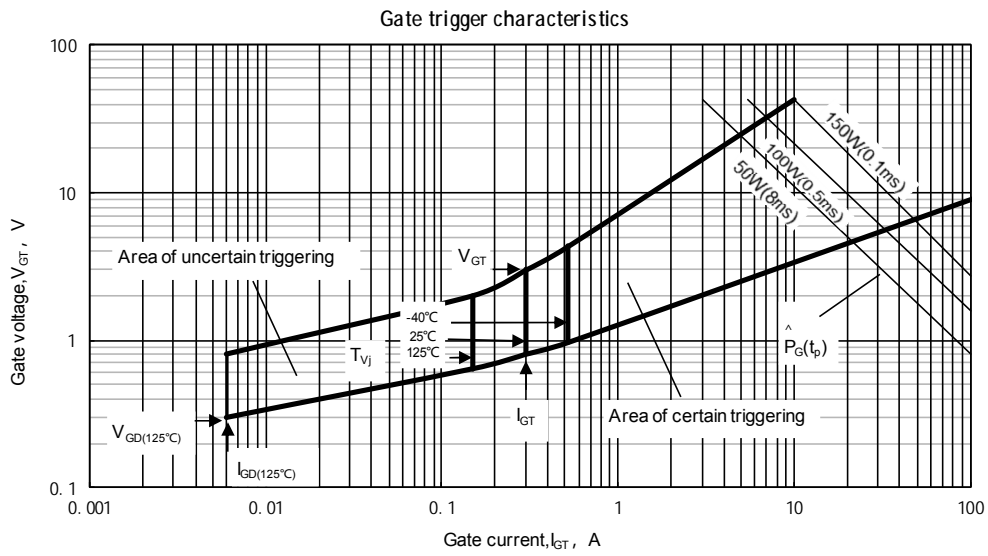
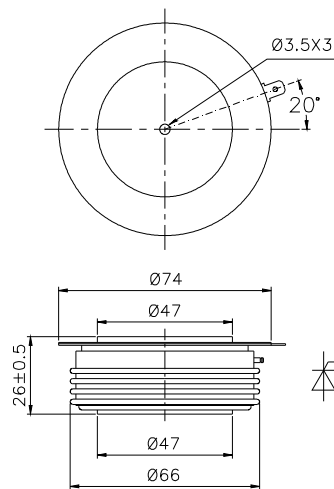

Fig.9

Outline:



DYNSEM reserves the right to change specifications without notice.