

Features

- n Center amplifying gate
- n Metal case with ceramic insulator
- n Low on-state and switching losses

Typical Applications

- n AC controllers
- n DC and AC motor control
- n Controlled rectifiers

Part No. DST1800-KT54cT

I_{T(AV)}	1760A
V_{DRM}, V_RRM	1200V 1400V
	1600V 1800V

SYMBOL	CHARACTERISTIC	TEST CONDITIONS	T _j (°C)	VALUE			UNIT
				Min	Type	Max	
I _{T(AV)}	Mean on-state current	180° half sine wave 50Hz Double side cooled, T _C =70°C	125			1760	A
V _{DRM} V _R RM	Repetitive peak off-state voltage Repetitive peak reverse voltage	tp=10ms	125	1100		1800	V
I _{DRM} I _{RRM}	Repetitive peak current	at V _{DRM} at V _R RM	125			100	mA
I _{TSM}	Surge on-state current	10ms half sine wave	125			26	kA
I ² t	I ² t for fusing coordination	V _R =0.6V _{RRM}				3380	A ² s*10 ³
V _{TO}	Threshold voltage		125			0.95	V
r _T	On-state slope resistance					0.18	mΩ
V _{TM}	Peak on-state voltage	I _{TM} =3000A, F=26kN	25			2.00	V
dv/dt	Critical rate of rise of off-state voltage	V _{DM} =0.67V _{DRM}	125			1000	V/μs
di/dt	Critical rate of rise of on-state current	V _{DM} = 67%V _{DRM} to2500A, Gate pulse t _r ≤0.5μs I _{GM} =1.5A	125			200	A/μs
Q _{rr}	Recovery charge	I _{TM} =1000A, tp=4000μs, di/dt=-20A/μs, V _R =100V	125		1500		μC
I _{GT}	Gate trigger current	V _A =12V, I _A =1A	25	40		300	mA
V _{GT}	Gate trigger voltage			0.8		3.0	V
I _H	Holding current			20		300	mA
I _L	Latching current					1000	mA
V _{GD}	Non-trigger gate voltage	V _{DM} =67%V _{DRM}	125			0.3	V
R _{th(j-c)}	Thermal resistance Junction to case	At 180° sine double side cooled Clamping force 26kN				0.018	°C /W
R _{th(c-h)}	Thermal resistance case to heatsink					0.004	
F _m	Mounting force			21		30	kN
T _{vj}	Junction temperature			-40		125	°C
T _{stg}	Stored temperature			-40		140	°C
W _t	Weight				590		g
Outline	KT54cT						

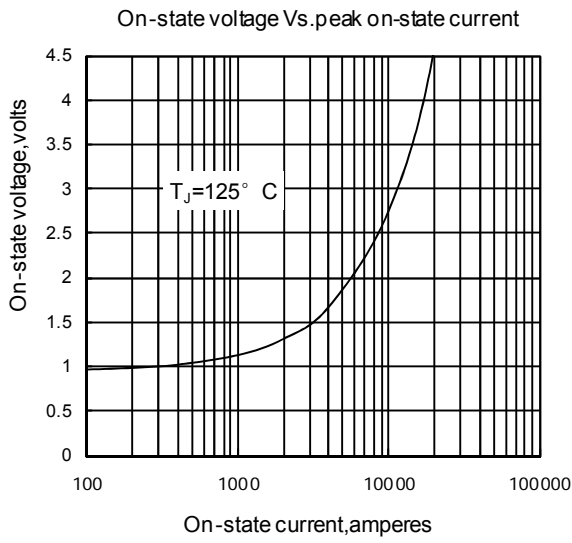

Fig1

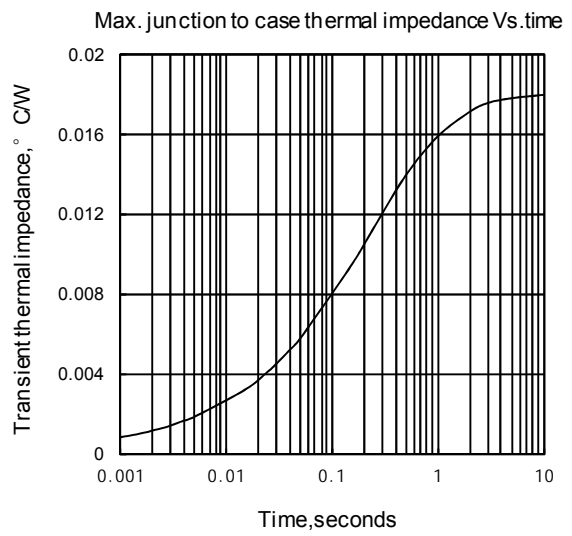

Fig2

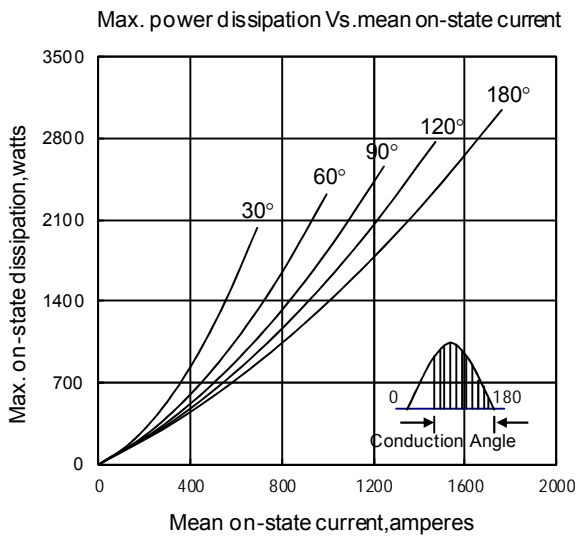

Fig3

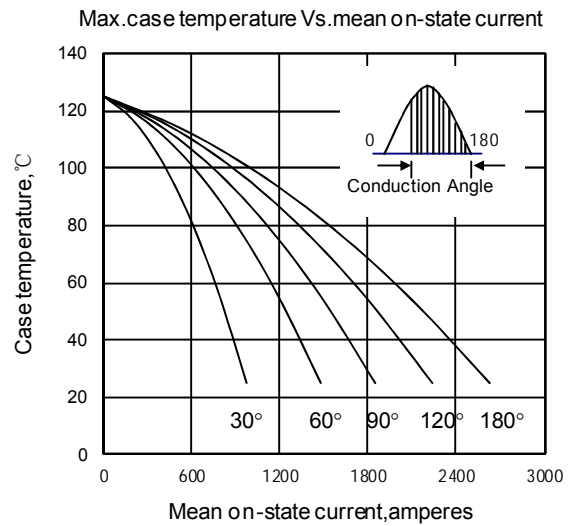

Fig4

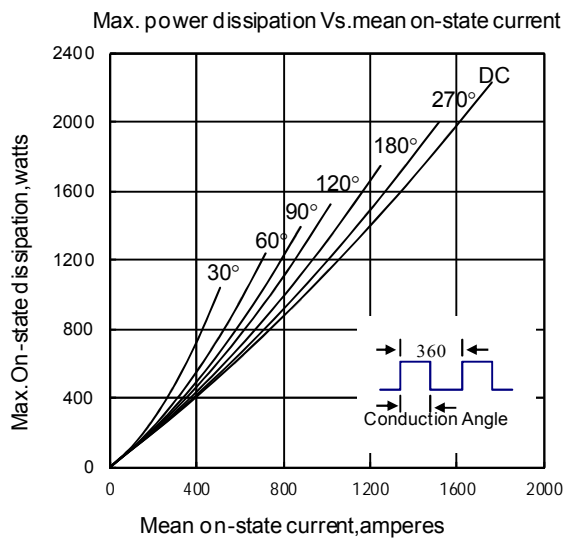

Fig5

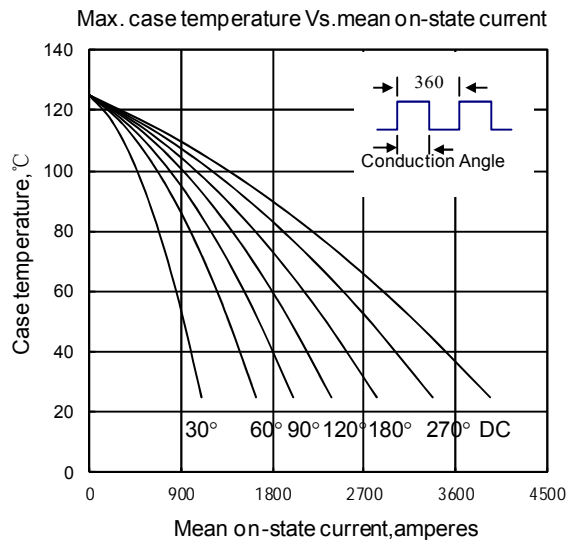

Fig6

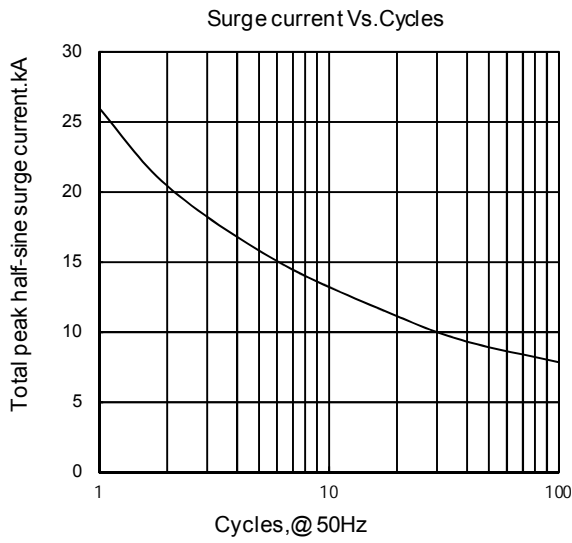

Fig 7

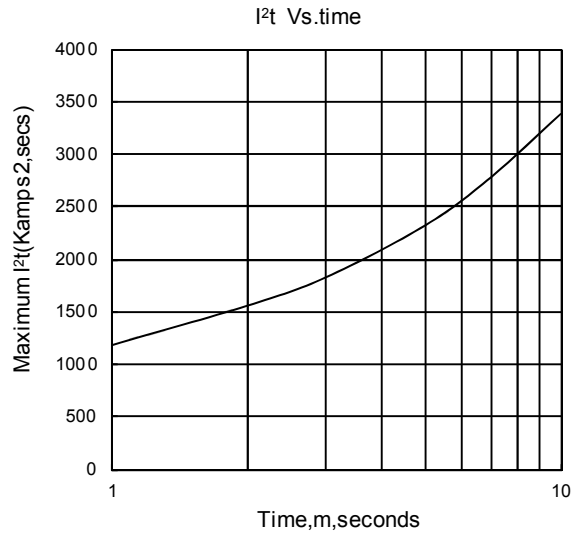

Fig 8

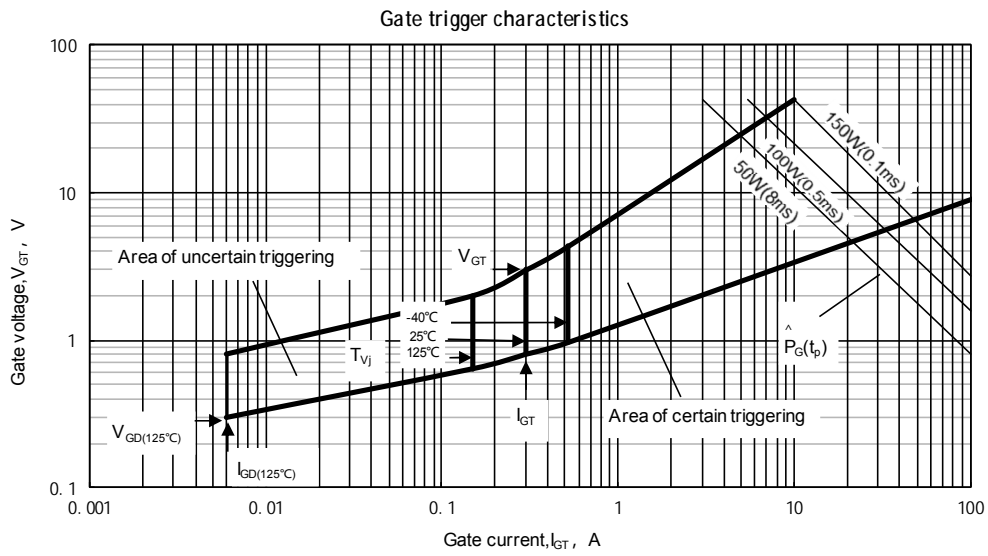
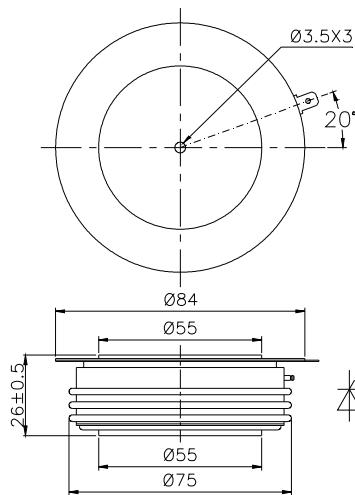

Fig.9

Outline:



DYNSEM reserves the right to change specifications without notice.